

Repair Parts Sheet	Revision	Revision Date	Product Code Beginning
L1762	G	09/23	RRH-1001: For Date Codes Beginning with the Letter "D" RCH-1003, RRH-1003, RRH-1006, RRH10010: For Date Codes Beginning with the Letter "E"

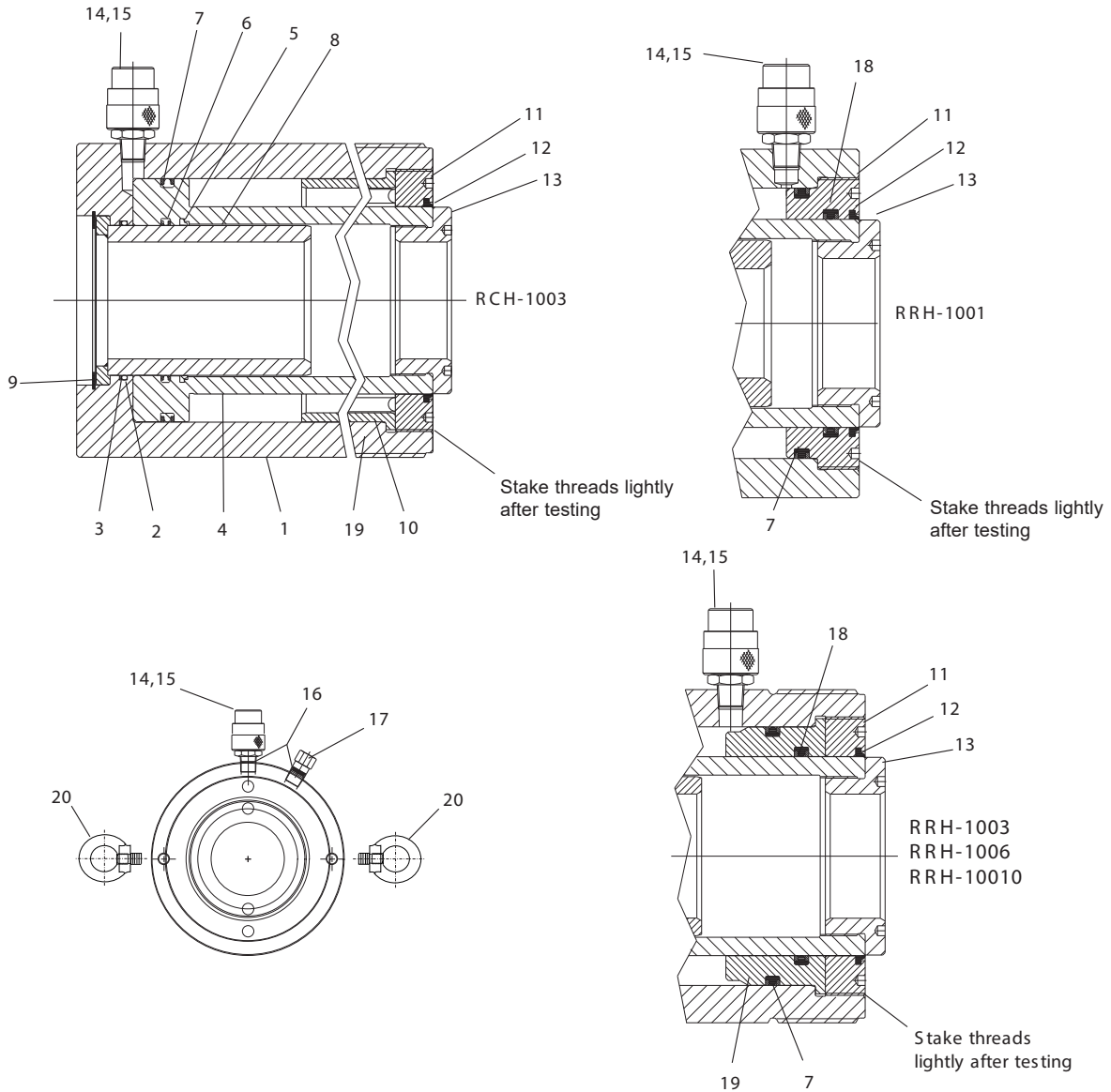

**Note: See Page 2  
for parts list.**

**(\*) Notes**

Item	Torque / notes
17	Safety valve must be preset to 11,000 to 11,500psi (760 to 795 bar)



**WARNING: STOP-RING ON RCH-1003 IS SPRING LOADED!** If not contained during disassembly, spring and stop-ring could cause personal injury.

Item	Description	Qty.	Part Number					Viton
			RCH-1003	RRH-1001	RRH-1003	RRH-1006	RRH-10010	
1	Cylinder	1	DA4249030	DA4329030	DA4249030	DA4314030	DA4314030	N/A
2	O-Ring	1	▶B1108503	▲B1108503	▲B1108503	▲B1108503	▲B1108503	▼B1242203
3	Back-Up Ring	1	▶DA4989566	▲DA4989566	▲DA4989566	▲DA4989566	▲DA4989566	▼DA4989566
4	Plunger	1	DA4250040	DA4328040	DA4250040	DA4785040	DA4785040	N/A
5	Wiper Ring	1	▶CF89044	▲CF89044	▲CF89044	▲CF89044	▲CF89044	▼CF651044
6	G-T Ring Assembly	1	▶B1345514	▲B1345514	▲B1345514	▲B1345514	▲B1345514	▼B1345516
7	G-T Ring Assembly (RCH-1003 use 1)	2	▶B1437513	▲B1437513	▲B1437513	▲B1437513	▲B1437513	▼B1437515
8	Center Tube	1	DA4247900	DA4326900	DA4247900	DA4797900	DA4313900	N/A
9	Retaining Ring	1	▶DA4270249	▲DA4270249	▲DA4270249	▲DA4270249	▲DA4270249	N/A
10	Spring	1	DA4265110	N/A	N/A	N/A	N/A	N/A
11	Stop Ring	1	DA4248044	DA4327044	DA4248044	DA4248044	DA4248044	N/A
12	Wiper Ring	1	▶G316044	▲G316044	▲G316044	▲G316044	▲G316044	▼CA557044
13	Saddle	1	DA4244045	DA4244045	DA4244045	DA4244045	DA4244045	N/A
14	Coupler (RCH-1003 use 1)	2	CR400	CR400	CR400	CR400	CR400	N/A
15	Dust Cap (RCH-1003 use 1) (Not Shown)	2	CD411	CD411	CD411	CD411	CD411	N/A
16	Plug (RCH Models Only)	2	A1009245	N/A	N/A	N/A	N/A	N/A
17	Relief Valve Assembly	1	N/A	CJ160900W	CJ160900W	CJ160900W	CJ160900W	N/A
18	G-T Ring Assembly	1	N/A	▲B1429514	▲B1429514	▲B1429514	▲B1429514	▼B1429516
19	Stop Tube, Inner Stop Ring	1	DA4591268	N/A	DA4311044	DA4311044	DA4311044	N/A
20	Eyebolt	2	BSS6355D	N/A	BSS6355D	BSS6355D	BSS6355D	N/A
	Repair Kit	1	RCH1003K4	RRH1001K4	RRH1001K4	RRH1001K4	RRH1001K4	N/A

▲:Indicates items included in, and available only in Repair Kit RRRH1001K4.

▼:Indicates items included in, and available only in Repair Kit RRRH1001K4V.

▶:Indicates items included in, and available only in Repair Kit RCH1003K4.



**To maintain your warranty,  
have your products inspected and repaired  
by an authorised Enerpac Service Centre**

[www.enerpac.com](http://www.enerpac.com)