

przecinarka do węży hydraulicznych

CUTTING | SERVICE | C300



FEATURES

Compact Design
 Hand Cutting
 Up to 2" 4SP Hydraulic Hose
 CE Approved

OPTIONS

12/24V DC
 Toothed blade
 110V/220V 1 Phase
 230V/440V/480V 3 Phase

C300

Dane techniczne przecinarki :

TECHNICAL DATA

Max. hose size (inch) ¹⁾	2
Diameter (blade) external (mm)	300
Diameter (blade) internal (mm)	50
Max. hose OD (mm)	80
Exhaust outlet OD (mm)	60
Motor Power (KW) ²⁾	3.0(400V 3 Phase)
Motor Power (HP) ²⁾	4.0

DIMENSIONS (LxWxH)

DIMENSIONS (LxWxH)		WEIGHT	
Machine (mm)	450x400x430	Machine (kg)	55
Machine (inch)	17.7x15.7x16.9	Machine (lbs)	121
Packaged (mm)	650x700x780	Packaged (kg)	75
Packaged (inch)	25.6x27.6x30.7	Packaged (lbs)	165

maksymalny wąż
 średnica tarczy
 średnica wewnętrzna tarczy
 maksyma średnica węża
 średnica odcigu
 zasilanie

wymiary maszyny

1) Hydraulic hose, 1-2 wire / 4 wire
 2) 3-phase / 1-phase

STANDARD FEATURES

Smooth blade

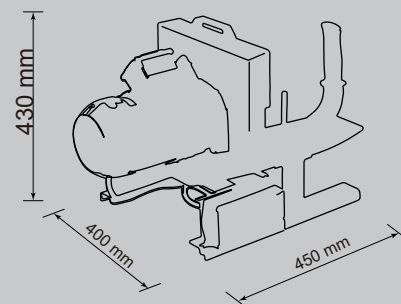

Products images & Specifications may alter prior official notice at any time.