



FEATURES

Vertical Crimping
 +80mm Opening
 Fast Crimping
 Up to 6" Hose

OPTIONS

110V/220V 1 Phase
 230V/440V/480V 3 Phase

PE88

TECHNICAL DATA

Crimping Range (mm) ¹⁾	6"
Opening without die (mm)	275
Opening with die (mm)	+80
Crimping Force (KN)	8000
Master Die length (mm)	200
Crimping Method	Crimping up and down (No moving forward or backward make the positioning much easier)
Crimping Speed	Fast
Motor (KW)	3 phase by ABB (220/400/440/480/660V) 7.5KW

DIMENSIONS (LxWxH)

Machine (mm)	920x580x1200
Machine (inch)	36.2x22.8x47.2
Packaged (mm)	1020x680x1350
Packaged (inch)	40.2x26.8x53.1

WEIGHT

Machine (kg/lbs)	1250/2756
Packaged (kg/lbs)	1330/2932

* ACCORDING TO THE FITTING.

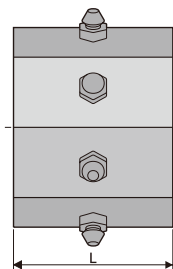
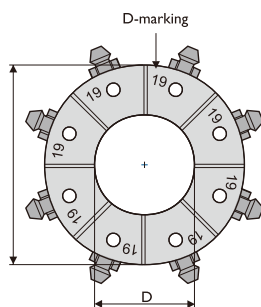

1) With standard dies. Crimping range can be increased with special dies.

CONTROL

Mirco Dail or Digital control as an Option

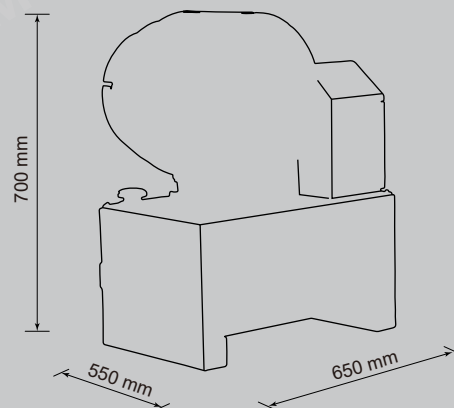

DIE SET 88-SERIES

DieSetNo	D (mm)	L (mm)	Crimp. range (mm)
*18506/10	10	60	10.0-12.0
*18506/12	12	60	12.0-14.0
18506/14	14	60	14.0-16.0
18506/16	16	60	16.0-19.0
18506/19	19	60	19.0-22.0
18506/22	22	75	22.0-26.0
18506/26	26	75	26.0-30.0
18506/30	30	75	30.0-34.0
18506/34	34	80	34.0-39.0
18506/39	39	80	39.0-45.0
18506/45	45	90	45.0-51.0
18506/51	51	90	51.0-57.0
18506/57	57	100	57.0-63.0
18506/63	63	100	63.0-69.0
18506/69	69	100	69.0-74.0
*18506/74	74	110	74.0-78.0
*18506/78	78	110	78.0-82.0

* Optional die sets at additional cost

Products images & Specifications may alter prior official notice at any time.