

przecinarka do węży

CUTTING | SERVICE | C450A



FEATURES

- Full protection
- Foot pedal control
- Direct Insert Hose From Front
- Enhanced Structure Stable Cutting
- CE Approved

OPTIONS

- Toothed blade
- 110V/220V 1 Phase
- 230V/440V/480V 3 Phase

C450A

TECHNICAL DATA

Max. hose size (inch) ¹⁾	2"6SP
Diameter (blade) external (mm)	300
Diameter (blade) internal (mm)	50
Max. hose OD (mm)	75
Exhaust outlet OD (mm)	100
Motor Power (KW) ²⁾	4.0(400V 3 Phase)
Motor Power (HP) ²⁾	5.4

DIMENSIONS (LxWxH)

WEIGHT

Machine (mm)	950x600x1150	Machine (kg)	180
Machine (inch)	37.4x23.6x45.3	Machine (lbs)	397
Packaged (mm)	1050x700x1320	Packaged (kg)	200
Packaged (inch)	41.3x27.6x52.0	Packaged (lbs)	441

1) Hydraulic hose, 1-2 wire / 4 wire
 2) 3-phase / 1-phase

STANDARD FEATURES

Foot Pedal Control

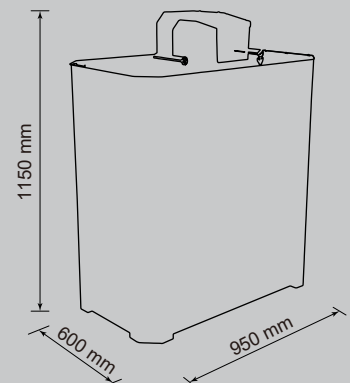

Products images & Specifications may alter prior official notice at any time.