



FEATURES

Foot Pedal Control
 2 way rotation
 Optional internal skiving tools
 CE Certified
 With Tool Holder

OPTIONS

110V/220V 1 Phase
 230V/440V/480V 3 Phase

CONTROL

By foot pedal

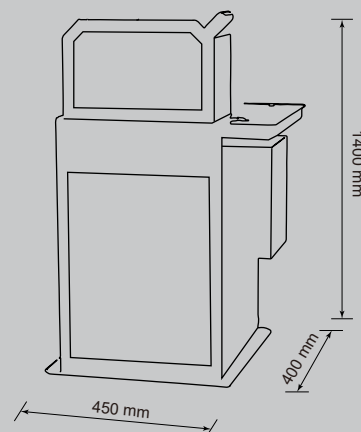

SKIVER 51ES

TECHNICAL DATA

Hose capacity, external (inch)	3/16-2
Hose capacity, internal (inch)	3/8-2
Speed of tool rotation (r./min)	100
Skiving length (mm)	100
Motor Power (KW/HP)	0.75/1.0(400V 3 Phase)

DIMENSIONS (LxWxH)

Machine (mm)	450x400x1400
Machine (inch)	17.7x15.7x55.1
Packaged (mm)	550x500x1500
Packaged (inch)	21.7x19.7x59.1

WEIGHT

Machine (kg/lbs)	100/220
Packaged (kg/lbs)	130/287

DESCRIPTION	Pno	Size (inches)	
INTERNAL TOOLS	715078	3/8	
	708937	1/2	
	707182	5/8	
	707167	3/4	
	707166	1	
	707179	1 1/4	
	707181	1 1/2	
EXTERNAL MANDRELS	707184	2	
	711313	3/16	
	711312	1/4	
	711311	5/16	
	711310	3/8	
	711321	1/2	
	711320	5/8	
	711319	3/4	
TOOL RACK WITHOUT TOOLS	711318	1	
	711314	1 1/4	
	711315	1 1/2	
	711317	2	
	TOOL RACK + MANDRELS	711331	
	707253		

Products images & Specifications may alter prior official notice at any time.