

## zakuwarka do nakrętek

CRIMPING | SERVICE | NC40



# NC40

TECHNICAL DATA	
Crimping range (mm) <sup>1)</sup>	12-105
Crimping range (inch) <sup>1)</sup>	0.47-4.13
Max. crimping force (KN)	930
Max. crimping force (tonnage)	93
Cycle time 10 mm (s) <sup>2)</sup>	1.9
Hose size ID (inch)	2
Die set series	NC20/30/40
Max. opening (mm) <sup>3)</sup>	+26
Max. opening without dies (mm)	166
Master die D/L (mm)	140/37
Master die D/L (inch)	3.90/1.46
Motor Power (KW/HP)	4.0/5.5 (400V 3 Phase)
Oil tank volume	50 L
Z-model availability	YES
DIMENSIONS (LxWxH)	
Machine (mm)	685x1000x940
Machine (inch)	27.0x39.4x37.0
Packaged (mm)	785x1100x1040
Packaged (inch)	30.9x43.3x40.9
WEIGHT	
Machine (kg/lbs)	450/992
Packaged (kg/lbs)	480/1058

DIMENSIONS (LxWxH)	
Standard (mm)	835x885x997
Standard (inch)	32.9x34.8x39.3
WEIGHT (KG/LBS)	
Standard	288/529

FEATURES	
Precision Digital Control	
Main Parts made in Germany	
Designed for Mass Production	
Energy Saving and Safety Operation	
Europe CE Approved	

- 1) With standard dies. Crimping range can be increased with special dies.
- 2) Theoretical with 10 mm cycle.
- 3) Maximum opening is the total die travel. Add this value to the minimum crimping diameter of the die set used. The result is the maximum opening of the machine with die set in place.

OPTIONS	
Adapter dies for NC20-series	
Adapter dies for NC30-series	
Foot pedal (Z-model)	
Auto greasing G3	
Oil Condition Monitoring OCM	
Quality control ICC3	
Graphical quality control ICC4	
Remote control unit R2	
Interface pack ETH	
A3 signal	
Bar Code Reader BCR	
110V/220V 1 Phase	
230V/440V/480V 3 Phase	

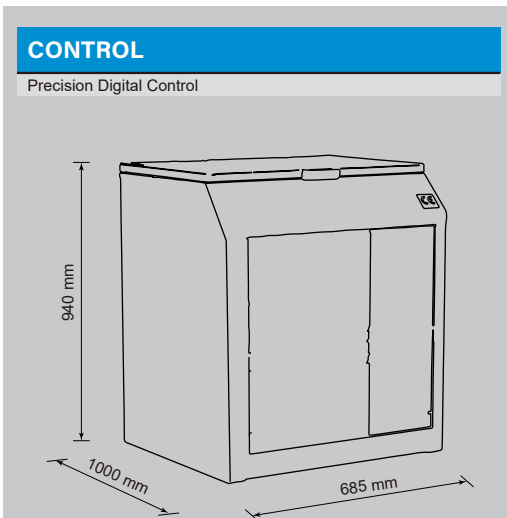

DIE SET NC20-SERIES			
DieSetNo	D (mm)	L (mm)	Crimp. range (mm)
18546/12	12	3	12.0-16.0
18546/16	16	4	16.0-22.0
18546/22	22	4.5	22.0-27.0
18546/27	27	5	27.0-34.0
18546/34	34	5	34.0-41.0
18546/41	41	5	41.0-49.0

DIE SET NC30-SERIES			
DieSetNo	D (mm)	L (mm)	Crimp. range (mm)
702044/12	12	3	12.0-14.0
702044/14	14	3	14.0-16.0
702044/16	16	4	16.0-19.0
702044/19	19	4	19.0-22.0
702044/22	22	4.5	22.0-26.0
702044/26	26	4.5	26.0-30.0
702044/30	30	5	30.0-34.0
702044/34	34	5	34.0-39.0
702044/39	39	5	39.0-45.0
702044/45	45	5	45.0-51.0
702044/51	51	5	51.0-57.0
702044/57	57	5	57.0-63.0

DIE SET NC40-SERIES			
DieSetNo	D (mm)	L (mm)	Crimp. range (mm)
703955/63	63	5	63.0-69.0
703955/69	69	5	69.2-73.0
703955/73	73	6	73.0-81.0
703955/81	81	7	81.0-93.0
703955/93	93	7	93.0-105.0

\* Optional die sets at additional cost

Products images & Specifications may alter prior official notice at any time.