

## zakuwarka do nakrętek

CRIMPING | SERVICE | NC50



### FEATURES

One-piece fitting Assembly  
 Automatic Push Out System  
 Supper Fast Production Speed

### OPTIONS

Foot pedal (Z-model)  
 Auto greasing G3  
 Oil Condition Monitoring OCM  
 Quality control ICC3  
 Graphical quality control ICC4  
 Remote control unit R2  
 Interface pack ETH  
 A3 signal  
 Bar Code Reader BCR  
 110V/220V 1 Phase  
 230V/440V/480V 3 Phase

### CONTROL

Precision Digital Control

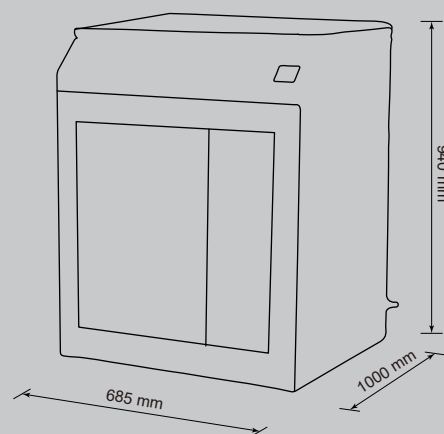

# NC50

TECHNICAL DATA	
Main application	Dedicated for 1 piece fitting for Parker or Similar
Max Hose Size	4"
Crimping Range (mm) <sup>1)</sup>	4-120
Die Type	P32, FP140
Max. Opening (mm) <sup>2)</sup>	+24
Master Die (Die / Length)	24
Motor (KW/HP)	7.5/10.1(400V 3 Phase)
Voltage (v)	220/380V/415/440/480V 3 Phase
Crimping Force (kN)	5000
Crimping Speed	7 sec./full cycle
Noise level (dB(A))	65
Protection Class	IP54
Adjustment Precision	0.01 mm
Hydraulic Oil cooler	Standard
Foot Pedal	Standard
Product Automatic Push-Out System	Optional
DIMENSIONS (LxWxH)	
Machine (mm)	685x1000x940
Machine (inch)	27.0x39.4x37.0
Hydraulic Unit (mm)	600x600x850
Hydraulic Unit (inch)	23.6x23.6x33.5
Packaged (mm)	785x1100x1040
Packaged (inch)	30.9x43.3x40.9

DIMENSIONS (LxWxH)	
Standard (mm)	835x885x997
Standard (inch)	32.9x34.8x39.3
WEIGHT (KG/LBS)	
Standard	288/529

- 1) With standard dies. Crimping range can be increased with special dies.
- 2) Maximum opening is the total die travel. Add this value to the minimum crimping diameter of the die set used. The result is the maximum opening of the machine with die set in place.

### DIE SET 32-SERIES

DieSetNo	D (mm)	L (mm)	Crimp. range (mm)
*18506/10	10	55	10.0-12.0
*18506/12	12	55	12.0-14.0
18506/14	14	55	14.0-16.0
18506/16	16	55	16.0-19.0
18506/19	19	55	19.0-22.0
18506/22	22	70	22.0-26.0
18506/26	26	70	26.0-30.0
18506/30	30	70	30.0-34.0
18506/34	34	75	34.0-39.0
18506/39	39	75	39.0-45.0
18506/45	45	90	45.0-51.0
18506/51	51	90	51.0-57.0
18506/57	57	100	57.0-63.0
18506/63	63	110	63.0-69.0
18506/69	69	110	69.0-75.0
*18506/74	74	110	74.0-80.0
*18506/78	78	110	78.0-87.0

### DIE SET 140-SERIES

DieSetNo	D (mm)	L (mm)	Crimp. range (mm)
18860/84/110	84	110	84.0-92.0
18860/92/110	92	110	92.0-100.0
18860/100/110	100	110	100.0-108.0
18860/108/110	108	110	108.0-116.0
18860/116/110	116	110	116.0-124.0

\* Optional die sets at additional cost

Products images & Specifications may alter prior official notice at any time.