



P16HP

PORTABILITY FOR SERVICE

SAMWAY P16HP is hand pump operated hydraulic crimping machine for repair workshops and field use. Easy to use, light and compact in size, allowing to be carried to any location. This hand-operated portable machine works even in places where electricity or compressed air are not available.

Available also with air pressure (AP-model) and separate head/power pack configuration (Z-model).

TECHNICAL DATA

Max crimping dia (mm/inch) ¹⁾	45/1.77
Max crimping dia with master dies (mm/inch)	49/1.9
Max crimping force (KN)	955
Max crimping force (tonnage)	95
Hydraulic hose size (inch)	1 *
Industrial hose size (inch)	1.77 *
Die set series	16
Max opening (mm) ²⁾	+20
Max opening without dies (mm)	59
Master die D/L (mm)	39/64
Master die D/L (inch)	1.54/2.52
Motor Power	Hand pump

DIMENSIONS (LxWxH)

Machine (mm)	330x400x280
Machine (inch)	13.0x15.7x11.0
Packaged (mm)	480x480x370
Packaged (inch)	18.9x18.9x14.6

WEIGHT

Machine (kg/lbs)	36/79
Packaged (kg/lbs)	38/84

* ACCORDING TO THE FITTING.

DIMENSIONS P16HPZ (LxWxH)

Crimping head (mm)	197x228x333
Crimping head (inch)	7.7x8.9x13.1
Hose length (metres)	4

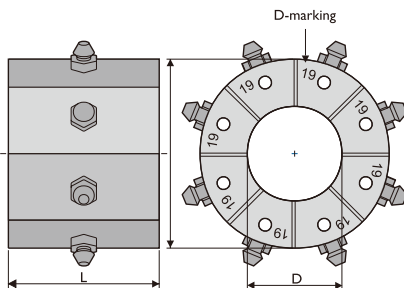

- 1) With standard dies. Crimping range can be increased with special dies.
- 2) Maximum opening is the total die travel. Add this value to the minimum crimping diameter of the die set used. The result is the maximum opening of the machine with die set in place.

FEATURES

- Portable 1"3 wire Crimper
- No electricity required
- Enerpac Hand Pump
- Complete Die Set

OPTIONS

- 220V 1 Phase / 400V 3 Phase electrical pump
- Pneumatic Pump
- Customized Die sets
- Customized Logo

CONTROL

Manual

MODELS

Z-model

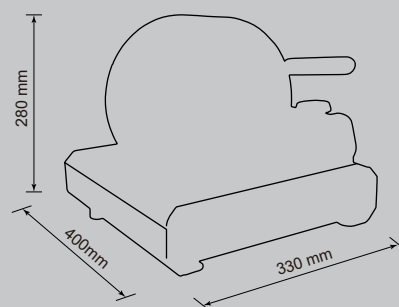

DIE SET 16-SERIES

DieSetNo	D (mm)	L (mm)	Crimp. range (mm)
18212/10	10	55	10.0-12.0
18212/12	12	55	12.0-14.0
18212/14	14	55	14.0-16.0
18212/16	16	55	16.0-19.0
18212/19	19	55	19.0-23.0
18212/23	23	55	23.0-27.0
18212/27	27	65	27.0-31.0
18212/31	31	65	31.0-38.0

* Optional die sets at additional cost

Products images & Specifications may alter prior official notice at any time.