

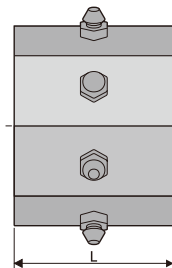

S201

TECHNICAL DATA	
Max crimping dia (mm/inch) ¹⁾	124/4.88
Max crimping dia with master dies (mm/inch)	150/5.9
Max crimping force (kN)	2400
Max crimping force (tonnage)	240
Cycle time 10 mm ²⁾	6.1
Hydraulic hose size (inch)	2 ½ *
Industrial hose size (inch)	4.88 *
Die set series	32/140
Max opening (mm) ³⁾	+24
Max opening without dies (mm)	164
Master die D/L (mm)	140/120
Master die D/L (inch)	5.52-4.73
Motor Power (KW/HP) ³⁾	4.0/5.5(400V 3 Phase)
Oil tank volume	80 L
DIMENSIONS (LxWxH)	
Machine (mm)	780x450x1500
Machine (inch)	30.7x17.7x59.1
Packaged (mm)	1040x1020x1560
Packaged (inch)	40.9x40.2x61.4
WEIGHT	
Machine (kg/lbs)	430/948
Packaged (kg/lbs)	480/1058
* ACCORDING TO THE FITTING.	

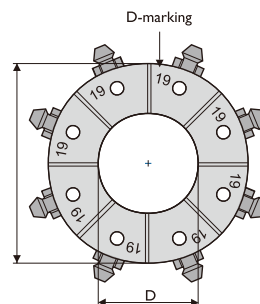

- 1) With standard dies. Crimping range can be increased with special dies.
- 2) Theoretical with 10 mm cycle.
- 3) Maximum opening is the total die travel. Add this value to the minimum crimping diameter of the die set used. The result is the maximum opening of the machine with die set in place.

FEATURES

Full Automatic Precision Control
 Affordable 6 inch Industrial Hose
 Energy Saving and Safety Operation
 CE Approved

OPTIONS

110V/220V 1 Phase
 230V/440V/480V 3 Phase

CONTROL

Advanced Programmable Chip

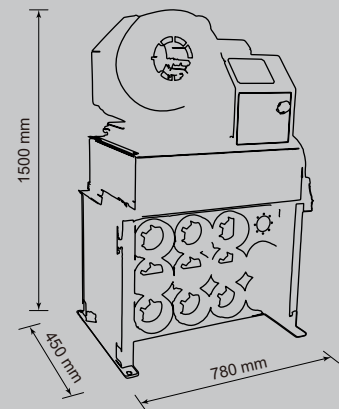

DIE SET 140-SERIES

DieSetNo	D (mm)	L (mm)	Crimp. range (mm)
18860/84	84	110	84.0-92.0
18860/92	92	110	92.0-100.0
18860/100	100	110	100.0-108.0
18860/108	108	110	108.0-116.0
18860/116	116	110	116.0-124.0

DIE SET 32-SERIES

DieSetNo	D (mm)	L (mm)	Crimp. range (mm)
*18506/10	10	55	10.0-12.0
*18506/12	12	55	12.0-14.0
18506/14	14	55	14.0-16.0
18506/16	16	55	16.0-19.0
18506/19	19	55	19.0-22.0
18506/22	22	70	22.0-26.0
18506/26	26	70	26.0-30.0
18506/30	30	70	30.0-34.0
18506/34	34	75	34.0-39.0
18506/39	39	75	39.0-45.0
18506/45	45	90	45.0-51.0
18506/51	51	90	51.0-57.0
18506/57	57	100	57.0-63.0
18506/63	63	110	63.0-69.0
18506/69	69	110	69.0-75.0
*18506/74	74	110	74.0-80.0
*18506/78	78	110	78.0-87.0

* Optional die sets at additional cost

Products images & Specifications may alter prior official notice at any time.