



FEATURES

Full Automatic Precision Control
 Affordable 6 inch Industrial Hose
 Energy Saving and Safety Operation
 CE Approved

OPTIONS

Backstop Device
 110V/220V 1 Phase
 230V/440V/480V 3 Phase

S76

TECHNICAL DATA

Max Hose	3"
Max Hydraulic Hose	2"6SP
Maximum Industrial Hose	120mm ID
Crimping Range (mm)	10-120
Die Type	51
Master Die Length (mm)	80
Max Opening (mm) ¹⁾	+24
Motor Power (KW/HP) ¹⁾	4.0/5.0(400V 3 Phase)
Crimping Force (KN)	2800
Crimpings Per Hour	550
Foot pedal	Included
Noise Level (dBA)	65
Protection Class	IP56

DIMENSIONS (LxWxH)

Machine (mm)	700x450x1350
Machine (inch)	27.6x17.7x53.1
Packaged (mm)	800x550x1500
Packaged (inch)	31.5x21.7x59.1

WEIGHT

Machine (kg/lbs)	370/816
Packaged (kg/lbs)	390/860

* ACCORDING TO THE FITTING.

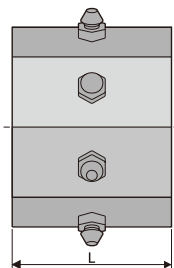
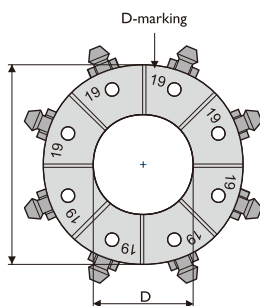

1) Maximum opening is the total die travel. Add this value to the minimum crimping diameter of the die set used. The result is the maximum opening of the machine with die set in place.

CONTROL

Advanced Programmable Chip

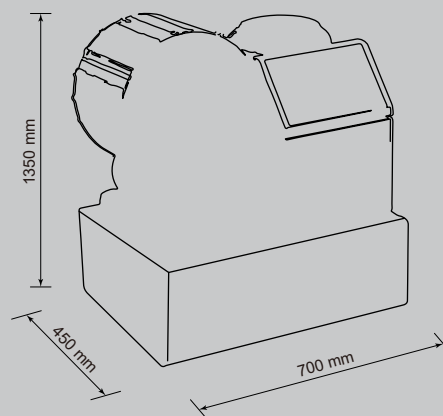

DIE SET 51-SERIES

DieSetNo	D (mm)	L (mm)	Crimp. range (mm)
*18506/10	10	60	10.0-12.0
*18506/12	12	60	12.0-14.0
18506/14	14	60	14.0-16.0
18506/16	16	60	16.0-19.0
18506/19	19	60	19.0-22.0
18506/22	22	75	22.0-26.0
18506/26	26	75	26.0-30.0
18506/30	30	75	30.0-34.0
18506/34	34	80	34.0-39.0
18506/39	39	80	39.0-45.0
18506/45	45	90	45.0-51.0
18506/51	51	90	51.0-57.0
18506/57	57	100	57.0-63.0
18506/63	63	100	63.0-69.0
18506/69	69	100	69.0-74.0
*18506/74	74	110	74.0-78.0
*18506/78	78	110	78.0-82.0

* Optional die sets at additional cost

Products images & Specifications may alter prior official notice at any time.