

giętarka do rur hydraulicznych

TUBE PROCESSING | SERVICE | T642



FEATURES

- Professional Tube Bending
- Special Tube Tool
- Optional Tube Deburring Tool
- Optional Flaring Tool

OPTIONS

- Deburring Modular
- Tube pre-assembly Modular
- 37 Flaring Modular
- 110V/220V 1 Phase
- 230V/440V/480V 3 Phase

T642

TECHNICAL DATA

Max capacity steel tube (mm)	6-42
Steel pipe	1/4 - 1 1/4"
Power (KW)	0.55(400V 3 Phase)

DIMENSIONS (LxWxH)

Machine (mm)	850x500x1100
Machine (inch)	33.5x19.7x43.3
Packaged (mm)	950x600x1250
Packaged (inch)	37.4x23.6x49.2

WEIGHT

Machine (kg/lbs)	100/220
Packaged (kg/lbs)	120/265

CONTROL

Electric

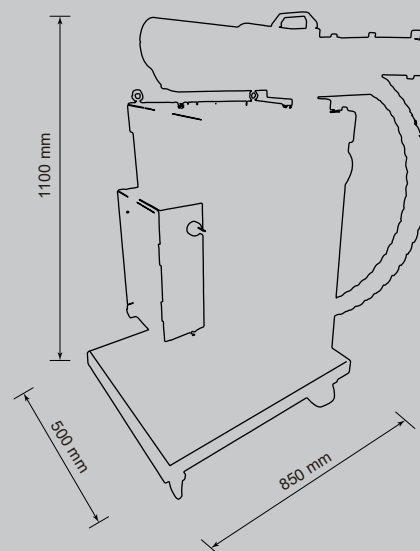

Products images & Specifications may alter prior official notice at any time.